

USER AND INSTALLATION MANUAL

MAG:CFX®

ENGLISH

/STADIUM BLOWER.®



CONFETTI FX

PART01899

rev 01-00

DISCLAIMER

⚠ WARNING

Read this manual carefully before installing and/or using this product. Failure to read the manual and to follow the printed instructions may lead to personal injury and/or damage to the product.

© 2020 MAGICFX®

All rights reserved.

Nothing from this publication may be copied, reproduced and/or published by means of printing, photocopying or by any other means, without the prior written approval of MAGIC FX.

MAGIC FX reserves the right to modify specifications stated in this manual.

TRADEMARKS

Any brand names mentioned in this manual are registered trademarks of their respective owners.

LIABILITY

MAGIC FX accepts no liability for claims from third parties arising from unauthorised use, use other than that stated in this manual, and use other than in accordance with the General Conditions registered at the Chamber of Commerce.

We further refer to the General Conditions. These are available on request, free of charge.

Although considerable care has been taken to ensure a correct and comprehensive description of all relevant components, the manual may nonetheless contain errors and inaccuracies.

Should you detect any errors or inaccuracies in the manual, we would be grateful if you would inform us. This helps us to further improve our documentation.

TABLE OF CONTENTS

Disclaimer	2
Trademarks	2
Liability	2
Foreword	4
Language	4
Revision table	4
1 Meet the MAGICFX® STADIUMBLOWER	5
1.1 Main parts	6
1.2 Technical data	7
1.3 Product identification	7
1.4 Manual mode	8
1.5 DMX control	8
1.6 Display panel	9
1.7 RDM capability	12
1.8 Accessories	13
1.9 Input & Output	13
2 Blow safely!	14
2.1 General safety rules	14
2.2 Transport	15
2.3 Indoor & outdoor use	15
2.4 Rigging	15
2.5 Noise level	15
2.6 Safety symbols	15
2.7 Precautions for operation	16
3 Let's blow!	17
3.1 Install the machine	17
3.2 Connect the machine	20
3.3 Setup multiple machines in a sequence	20
3.4 Fill with confetti	21
3.5 Blow with DMX or manual mode	22
3.6 Clean up	24
4 Maintenance	24
4.1 Roller replacement	24
5 Troubleshooting	29
6 EC Declaration of Conformity	31

FOREWORD

Congratulations! You have bought a great new product from MAGIC FX.

This manual contains all information required for the intended use of the equipment. Deviation from the described intended use can result in a hazardous situation and/or property damage.

This manual includes notes and warnings on safe operation of the equipment. These notes and warnings are accompanied by the following icons. Read them attentively!

⚠ DANGER

Indicates a hazardous situation that, if not avoided, will result in death or serious injury. This signal word is to be limited to the most extreme situations.

⚠ WARNING

Indicates a hazardous situation that, if not avoided, could result in death or serious injury.

⚠ CAUTION

Indicates a hazardous situation that, if not avoided, could result in minor or moderate injury.

NOTICE

Indicates information considered important, but not hazard-related (e.g. messages relating to property damage).

LANGUAGE

This document contains the original instructions in English. In case you require other languages please contact MAGIC FX.

REVISION TABLE

Doc nr	Revision	Date	Description	Author	Approved
PART01899	01-00	17-11-2020	Initial release	NVE	PW

1 MEET THE MAGICFX® STADIUMBLOWER

The MAGICFX® STADIUMBLOWER is a special effect machine that blows confetti into the air using a powerful electric blower. Distances up to 15 meters can be reached!

The MAGICFX® STADIUMBLOWER is equipped with a especially designed venturi nozzle and has two separated confetti hoppers. Each hopper has its own foam roller that can be controlled individually and together as one.

Adjusting the speed of the foam rollers gives you full control over the effect density.

The MAGICFX® STADIUMBLOWER is outfitted for operation:

- In manual mode with multiple options (e.g. setting a timer and the output density);
- With DMX and optionally RDM;
- In sequence with multiple machines.

1.1 MAIN PARTS

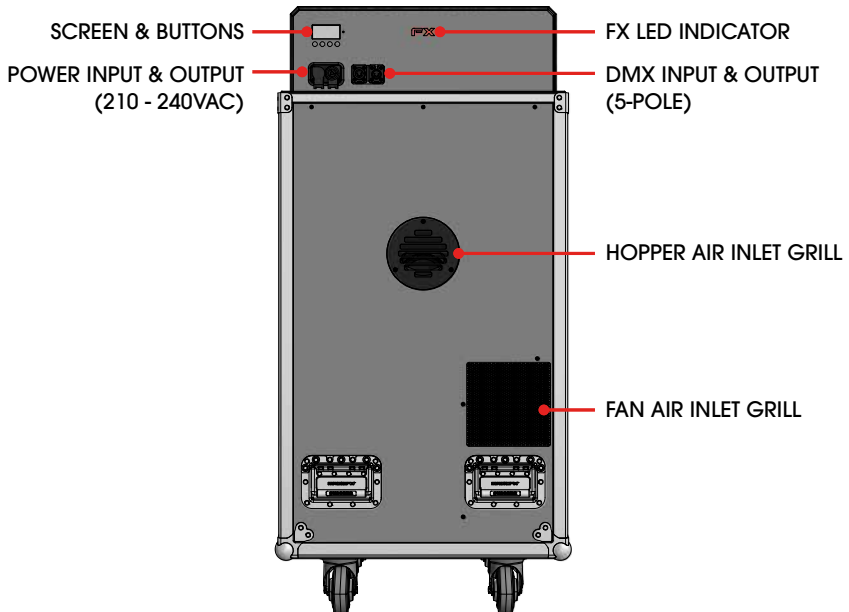
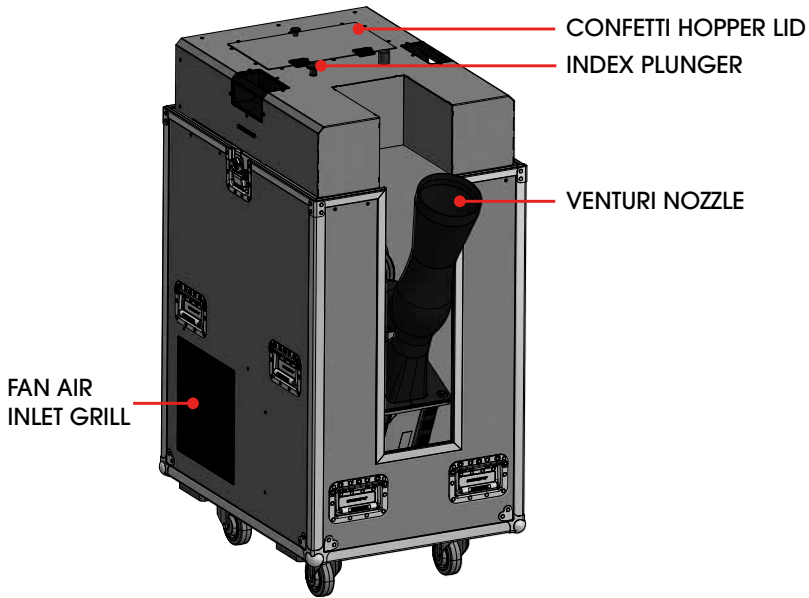

1.2 TECHNICAL DATA

Product	Product Name	MAGICFX® STADIUMBLOWER	
	Product Code	MFX0502	
	Product Type	CONFETTI FX	
Main Dimensions	Length	800 mm	31.5 in
	Width	600 mm	23.6 in
	Height	1315 mm	51.77 in
Weight	Weight	104 kg	229.3 lb
Environment	Minimum Temperature	0 °C	32 °F
	Maximum Temperature	50 °C	122 °F
	Humidity (Relative)	20 % to 90 % (non condensing)	
	IEC 60529 (IP) Rating	-	
Electrical	Voltage Input	210 - 240 Vac	
	Voltage Frequency	50 - 60 Hz	
	Power Consumption	1400 W	
	Power Connector	Neutrik® powerCON TRUE1 (in & out)	
Controlling	Control Options	DMX / Manual mode / Timer	
	Control Protocols	DMX512-A (ANSI E1.11) RDM (ANSI E1.20)	
	Control Connectors	Neutrik® 5 pole male / female XLR	
Configuring	Configure Options	On Device & RDM	
Usage	Consumable(s)	MAGICFX® CONFETTI	
	Consumption Rate	Depends on type of confetti, see Section 1.9	

Technical data

1.3 PRODUCT IDENTIFICATION



Type plate

1.4 MANUAL MODE

Manual mode gives the user the possibility to control the machine without the need for DMX or an external lighting console. A simple sequence of effect on and off times, and desired distance and density can be set via the manual mode menu on the display panel.

Manual operation menu items	Values
Manual mode	ON / OFF
Run timer	1 – 600 (s)
Pause timer	0 – 600 (s)
Hopper 1 (effect density)	0 – 255
Hopper 2 (effect density)	0 – 255

Manual mode

1.5 DMX CONTROL

When connected to DMX the MAGICFX® STADIUMBLOWER is controlled with 1 safety address and 3 operational addresses:

DMX address	Address range
Enable address	1 – 512
Start address + 1 (hopper 1 roll)	2 - 512
Start address + 2 (hopper 2 roll)	3 – 512

DMX addresses

The safety address cannot be the same as (one of) the operational address(es). Operating of these addresses results in the following:

DMX address	DMX value (decimal)		Result
Enable address	0	99	Device disabled
	100	155	Device enabled
	156	255	Device disabled
Start address + 1 (hopper 1 roll)	0	9	No effect
	10	255	Variable output
Start address + 2 (hopper 2 roll)	0	9	No effect
	10	255	Variable output

Operation of the DMX addresses

When you link multiple machines with DMX, we advise you to use the same safety address for all machines.

CAUTION

Always plug in a DMX Terminator into the DMX output of the final unit in the control sequence. Using a DMX Terminator improves signal reliability.

1.6 DISPLAY PANEL

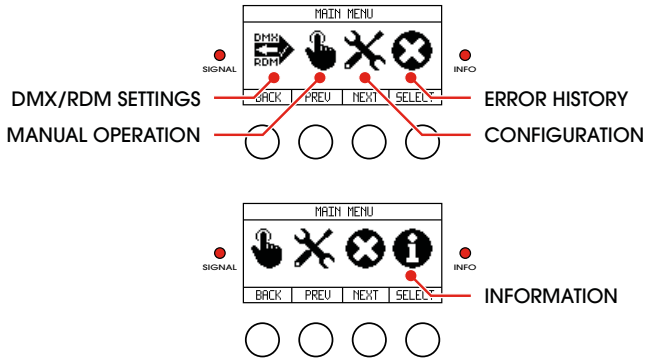

Display panel

The display panel is located on the backside of the MAGICFX® STADIUMBLOWER.

Check the following menu structure for all options in the menu. Use the buttons for navigation and selection. The left-hand LED blinks red when DMX is active. The right-hand LED continuously lights red when an error is present.

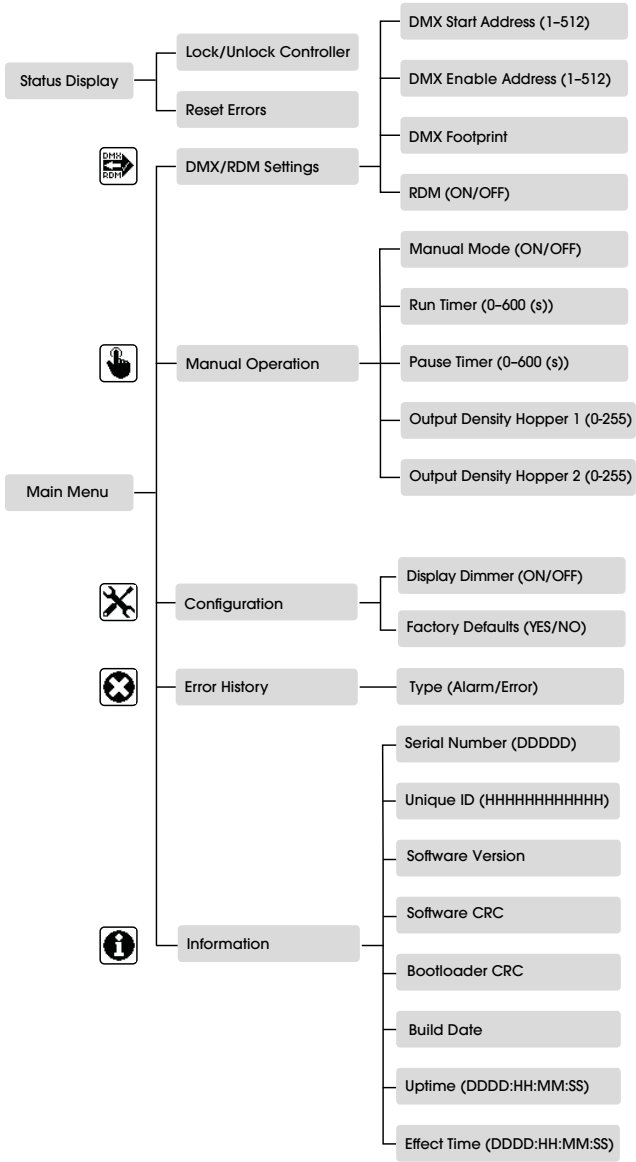

Menu function	Explanation
Lock/Unlock Controller	Holding the Lock button for more than 5 seconds will “lock” the display functions. Meaning buttons will not respond. This to avoid accidental change of parameters via display. To unlock, hold the Unlock button for more than 5 seconds.
Reset Errors	In case there is a locking error present, this button will reset the appliance. If the fault does not persist, the locking error will not reappear.
DMX Start Address (1-512)	Setting the DMX start address.
DMX Enable Address (1-512)	Setting the DMX enable address.
DMX Footprint	This parameter indicates the DMX footprint, in other words the amount of sequential channels used by the appliance. This does not include the safety channel.
RDM (On/Off)	Use this function to turn on/off the RDM functionality.
Manual Mode (On/Off)	This turns manual mode on or off. Via manual mode the user is able to control the STADIUMBLOWER without the need for a DMX lightning console.
Run Timer (sec) (1-600)	When the Pause Timer is set to 0, the manual mode runs continuously. The Run Timer value doesn't have any effect in this.
Pause Timer (sec) (0-600)	When this timer is set to 0, manual mode runs continuously.
Output Density Hopper 1 (0-255)	Setting of the effect density. The 0-255 range is comparable to the lighting console fader running from 0 up to 255.
Output Density Hopper 2 (0-255)	Setting of the effect density. The 0-255 range is comparable to the lighting console fader running from 0 up to 255.
Display Dimmer (On/Off)	Turn display dimmer on or off. If turned on, the display is dimmed automatically 30 seconds after the last button push.
Factory Defaults (Yes/No)	Restores the appliance factory default settings.
Type (Alarm/Error)	Toggle between the occurred locking error (Alarm) list, and blocking error (Error) list. Locking errors need intervention by user, although they are “auto-reset” 3 times before the appliance remains in error until reset by user. Blocking errors clear when the triggering fault disappears. 16 locked, and 16 blocked errors are logged. Top of the list shows the last occurring error.
Serial Number (DDDDD)	Appliance serial number as also printed on the appliance label.
Unique ID (HHHHHHHHHH)	UID number as the appliance appears in the RDM device list after running discovery.
Software Version	Installed software version.

Software CRC	CRC of the functional software.
Bootloader CRC	CRC of the bootloader software.
Build Date	Release date of functional software.
Up-Time (DDD:HH:MM:SS)	Time counter which indicates how long the appliance has been powered in total.
Effect-Time (DDD:HH:MM:SS)	Time counter which indicates how long the effect has been activated.

Menu functions

1.7 RDM CAPABILITY

Remote Device Management Protocol (RDM) is an enhancement of the DMX512 communication protocol. RDM can be used for configuration and status monitoring while DMX512 takes care of the default controlling. For RDM you will need a RDM compatible controller. The following RDM parameters are supported by the MAGICFX® STADIUM BLOWER.

Parameter ID	Discovery	GET	SET
DISC_UNIQUE_BRANCH	X		
DISC_MUTE	X		
DISC_UN_MUTE	X		
DEVICE_INFO		X	
SUPPORTED_PARAMETERS		X	
SOFTWARE_VERSION_LABEL		X	
DEVICE_MODEL_DESCRIPTION		X	
MANUFACTURER_LABEL		X	
SLOT_DESCRIPTION		X	
DMX_START_ADDRESS		X	X
IDENTIFY_DEVICE		X	X
DEVICE_LABEL		X	X
FACTORY_DEFAULTS		X	X
RESET_DEVICE			X

RDM parameters

RDM parameters are subject of change due to software updates. Contact MAGIC FX for the latest information and updates.

1.8 ACCESSORIES

Code	Product	Included
MF0313	SCHUKO TO NEUTRIK® POWERCON TRUE1 - CABLE 1.5 m	
MF0503	STADIUMBLOWER RAIN COVER	

Accessories

Please contact MAGIC FX for additional possibilities.

1.9 INPUT & OUTPUT

The venturi nozzle can be set in 5 different angles between 5° upwards, till 45° forward.

The output height and output distance depends on the type of confetti and the set angle. The maximum load per blast also depends on the type of confetti. Check the following table.

Consumable	Shape	Max. load each hopper	Max. output distance at 45°		Consumption
MAGICFX®	55x17 mm	2 kg	10 m	33 ft	± 1 kg/min
	10x10 mm	1 kg	10 m	33 ft	± 0,75 kg/min
PAPER CONFETTI	6x6 mm	1 kg	10 m	33 ft	± 0,75 kg/min
	Shapes	2 kg	10 m	33 ft	± 0,5 kg/min
	Crunch Snow	0,5 kg	10 m	33 ft	± 0,5 kg/min
MAGICFX®	55x17 mm	3 kg	10 m	33 ft	± 2 kg/min
	6x6 mm	2 kg	10 m	33 ft	± 1,5 kg/min
METALLIC CONFETTI	Shapes	3 kg	10 m	33 ft	± 2 kg/min

Confetti types and related loads and output*

⚠ WARNING

Using any other objects other then MAGICFX® CONFETTI can lead to death or serious injury.

NOTICE

Wind and other weather circumstances will influence the output distance. The given values are estimated values.

NOTICE

The estimated consumption values may deviate due the unpredictable state of confetti placed inside the hopper.

2 BLOW SAFELY!

The machine has been designed and constructed in such a manner that it can be used safely. This applies to the use, the circumstances and the regulations as described in this documentation. Reading this documentation and following the instructions are therefore necessary for everyone who is authorised to work with the machine.

The machine must be used in surroundings that:

- Have a stable temperature of between 0 and 50 °C.
- Have a relative humidity degree between 20 % and 90 % (non condensing).
- Are free of dust, corrosive gases and high concentrations of organic vapours.
- Are not situated in the vicinity of a source of vibration.

2.1 GENERAL SAFETY RULES

- Only authorised persons may carry out work with the MAGICFX® STADIUMBLOWER.
- Do not use the MAGICFX® STADIUMBLOWER if there are people or animals in the direct output.
- Do not use the MAGICFX® STADIUMBLOWER if alterations have been made other than by or on behalf of MAGICFX®.
- Make sure that children, unauthorised people and animals do not obtain access to the MAGICFX® STADIUMBLOWER.
- Make sure there are no free-standing objects or objects that can be damaged by the machine within the output distance.
- Make sure that confetti cannot come into contact with high-voltage lines/power pylons, as this can result in electrocution.
- Do not connect more units to a single electrical circuit than the installed fuse is able to handle. (Calculate the summed load with the electrical data from Chapter 1)
- Do not remove any safeguards, safety caps and safety symbols.
- All required safety devices must be in good condition and function properly.
- Ensure sufficient lighting of the surroundings.
- Keep the workplace clean.

2.2 TRANSPORT

- Clean the device, make sure there is no confetti left inside the device.
- When the device is stored for a longer period of time (exceeds 5 days), make sure there is no liquid inside the flightcase.

2.3 INDOOR & OUTDOOR USE

The MAGICFX® STADIUMBLOWER is designed for indoor and outdoor use.

⚠ WARNING

The machine can not be used in rain or other wet conditions with any fluids.

2.4 RIGGING

Please follow the European and national guidelines for safe rigging and trussing.

2.5 NOISE LEVEL

The measured maximum noise level of the product is 92 dB(A) at 1 m distance away. This level of noise is only reached during the short instances that the output is active. Please follow the European and national guidelines regarding hearing protection.

2.6 SAFETY SYMBOLS

Symbol	Meaning
	Read the manual carefully before use!
	Rotating parts, risk of pinch! Keep hands and other body parts clear.



Safety symbols

2.7 PRECAUTIONS FOR OPERATION

⚠ WARNING

Using a damaged or an improper installed machine can lead to death, serious injury or property damage. Always inspect the machine thoroughly before operation.

⚠ WARNING

Unauthorized operation of the machine can lead to death, serious injury or property damage. Never leave the machine unattended when the machine is ready for use.

⚠ WARNING

Do not use the MAGICFX® STADIUMBLOWER if alterations have been made other than by or on behalf of MAGICFX®.

⚠ DANGER

Make sure that confetti cannot come into contact with high-voltage lines/power pylons, as this can result in electrocution.

⚠ WARNING

Missing or obscured safety symbols on the machine can lead to death, serious injury or property damage. Make sure all safety symbols are correctly in place and visible, see Section 2.7.

⚠ WARNING

Make sure there are no objects near the input grills that can block the air to be sucked in.

⚠ WARNING

Make sure there are no objects near the output that can be damaged or overthrown by the MAGICFX® STADIUMBLOWER.

⚠ WARNING

Always keep the output zone as shown in the image below clear of all people, animals and objects. Not doing so results in death or serious injury.

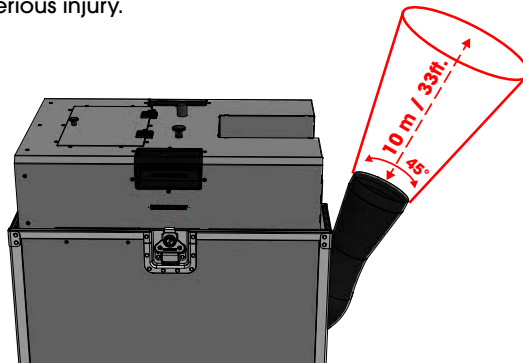

3 LET'S BLOW!

3.1 INSTALL THE MACHINE

- 1 Bring the cased machine to the desired location.

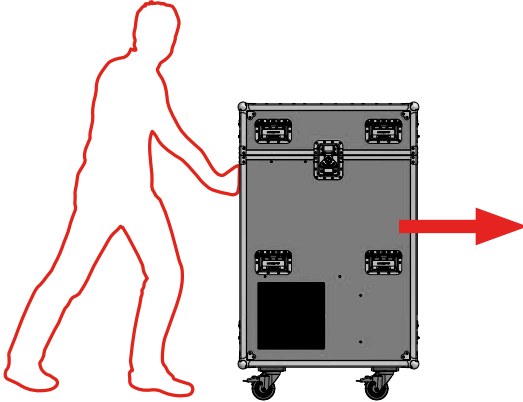

- 2 Place the machine in its final position and set the brakes.

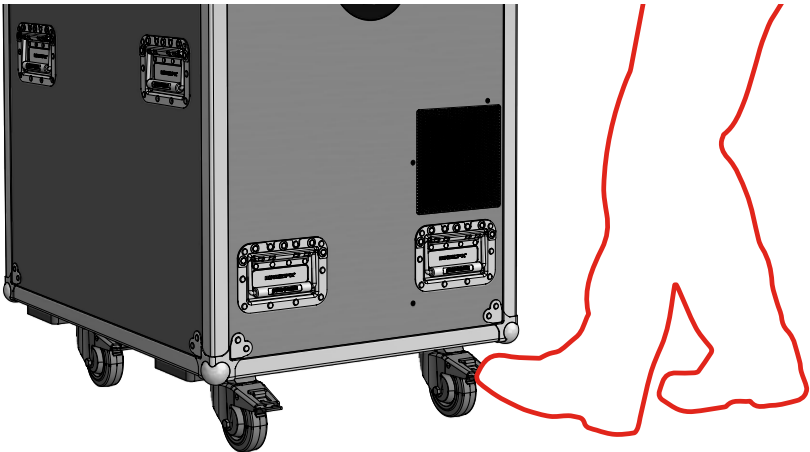

-
- 3 Unlock and remove the flightcase cover.

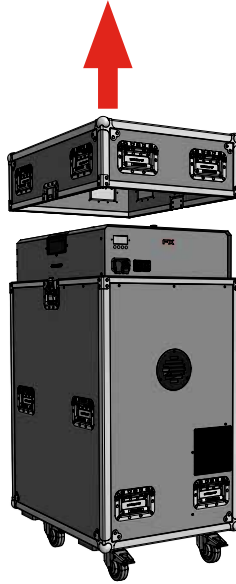

-
- 4 Remove the slide panel.

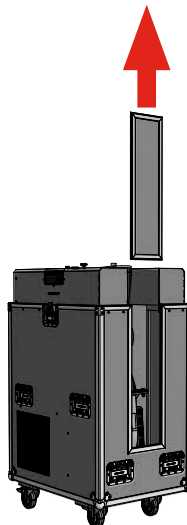

-
- 5 Pull the index plunger and set the venturi nozzle in the desired position. Make sure the index plunger is properly in place and the venturi nozzle is locked.

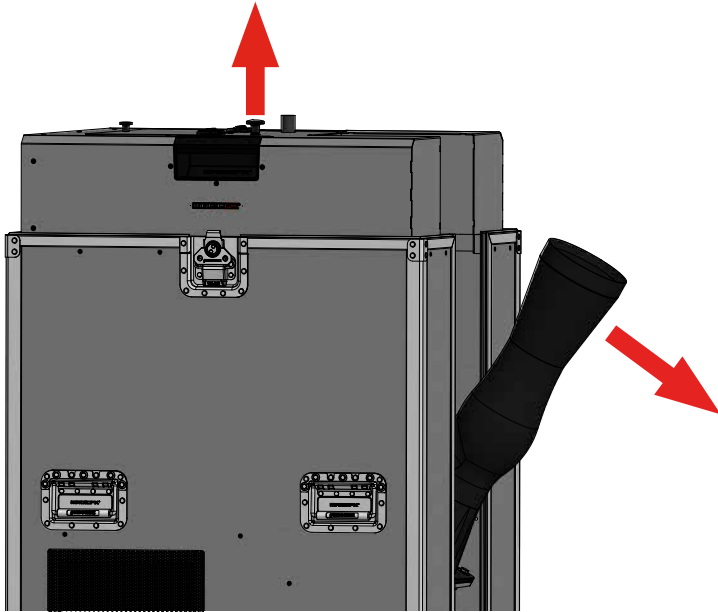

⚠ WARNING

Never use the machine when the index plunger is not properly in place or working properly. Not doing so can result in serious injury or death.

- 6 Take the necessary safety precautions, see Section 2.7.
-

3.2 CONNECT THE MACHINE

- 1 If DMX is used, follow the next steps:

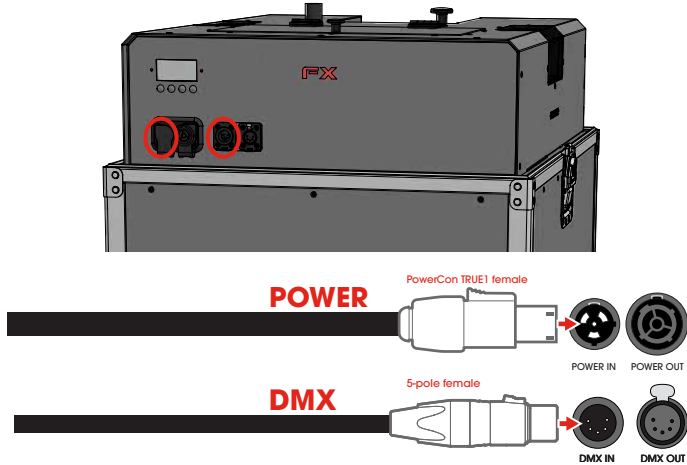

1. Connect a power cable with a PowerCon TRUE1 female connector to a 210-240 Vac (50-60 Hz) power source.
 2. Connect the other end of the power cable to the power input. The screen will light up.
 3. Connect the female connector of a 5-pole DMX cable in the DMX input.
 4. Connect the other end of the DMX cable to the DMX controller.
 5. Use the display and buttons or a RDM controller to assign DMX addresses, see Chapter 1.
-

3.3 SETUP MULTIPLE MACHINES IN A SEQUENCE

⚠ CAUTION

Do not connect more units to a single electrical circuit than the installed fuse is able to handle. (Calculate the summed load with the electrical data from Chapter 1)

NOTICE

Always plug in a DMX Terminator into the DMX output of the final unit in the control sequence. Using a DMX Terminator improves signal and reliability.

-
- 1 Optionally connect another machine to the power output with a power link cable. If DMX is used, follow the next steps:

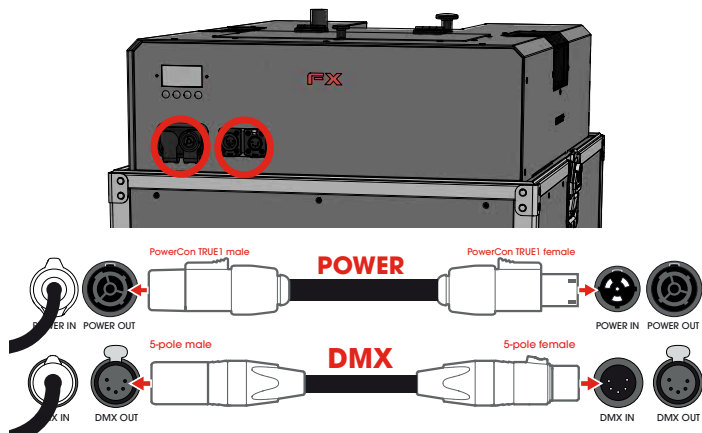

1. Connect a power link cable between the power output and the power input of the next machine.
2. Connect a DMX cable between the DMX output and the DMX input of the next machine.
3. Use the buttons or a RDM controller to assign DMX addresses, see Chapter 1.
4. Repeat step 1 to 3 for each subsequent machine.

3.4 FILL WITH CONFETTI

⚠ WARNING

Make sure the rollers are not turning when filling up the machine.

- 1 Open the lid.

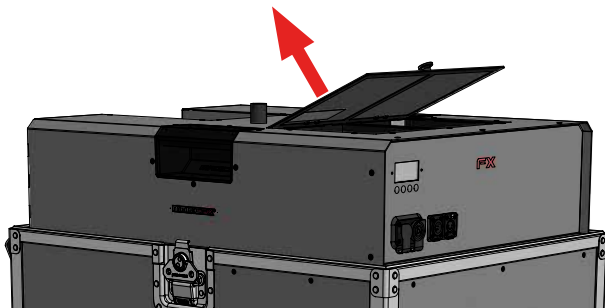

-
- 2 Fill 1 or 2 hoppers with confetti.
Check Chapter 1.9 for the maximum amount of each type of MAGICFX Confetti.

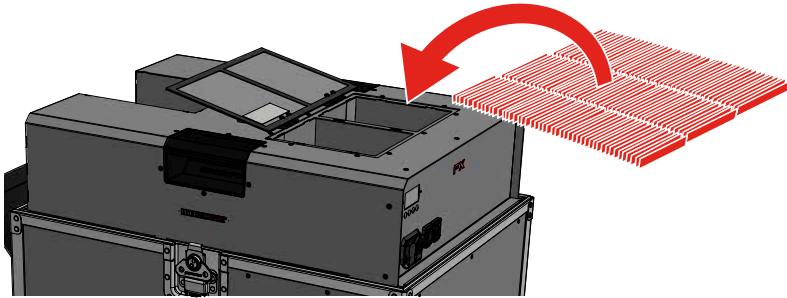

-
- 3 Close the lid.

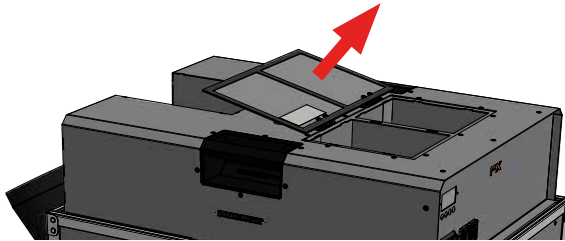

3.5 BLOW WITH DMX OR MANUAL MODE

⚠ DANGER

Make sure that the described safety zone is clear of people, animals and objects. Not doing so results in death or serious injury.

If **DMX** is used, follow the next steps:

1. Make sure that the prescribed safety zone is free from persons and objects.
2. Make sure that the air inlet grilles are free of any objects.
3. Activate the enable address. The FX LED indicator on the machine lights up.
4. Activate the effect by setting the DMX value of hopper 1 and/or hopper 2.
The effect density can be regulated anywhere between 10 and 255. By activating one or both hoppers, the fan will start blowing
5. Vary the effect density of each hopper during the effect duration, if desired.
6. Enjoy the view!

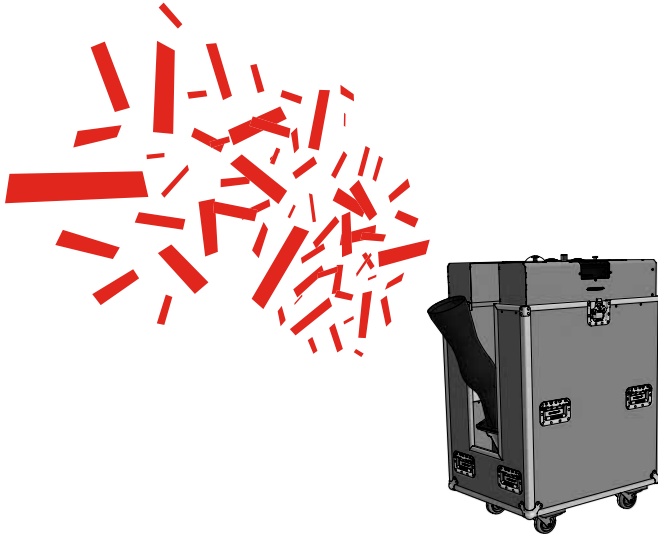

-
7. To deactivate, change the DMX values of both effect density channels to a value below 10, then deactivate the enable address. The FX LED indicator dims.

If manual mode is used, follow the next steps:

1. Power up the machine (if manual mode is ON, the machine starts blowing instantly)
2. Use the display and buttons to create the desired output in manual mode, see Chapter 1.6.
3. Make sure that manual mode is ON.
4. Enjoy the view!
5. To stop the effect set manual mode OFF or switch the machine OFF.

⚠ WARNING

Please note that the manual settings will be retained even after turning off and on the machine. This includes manual mode OFF/ON.

3.6 CLEAN UP

⚠ WARNING

Make sure the power is off and the rollers are not turning when cleaning the machine.

- 1 Disconnect the cables, place the True1 protection caps.

- 2 Pull the index plunger and set the venturi nozzle in the most vertical position. Make sure the index plunger is properly in place and the venturi nozzle is locked.

- 3 Remove any remaining confetti from the hopper and from in/outside the machine.

- 4 Place the slide-in-panel and place the top-panel. make sure to lock the flightcase cover.

- 5 Release the brakes.

4 MAINTENANCE

To achieve the maximum service life of the machine you must regularly clean the machine. Contact MAGIC FX if the machine is not functioning correctly.

⚠ DANGER

Do not replace parts yourself other than specified in this chapter; always consult MAGIC FX.

4.1 ROLLER REPLACEMENT

If the rollers are up to a replacement it is possible to replace them using the manual below. If you are unsure whether replacement is needed please contact MAGIC FX.

Code**Product**

SPR01906

STADIUMBLOWER Foam Roll

Needed Spare parts

⚠ WARNING

Make sure the power is off and the rollers are not turning when cleaning the machine.

Remove the index plunger button by turning it counter clockwise.

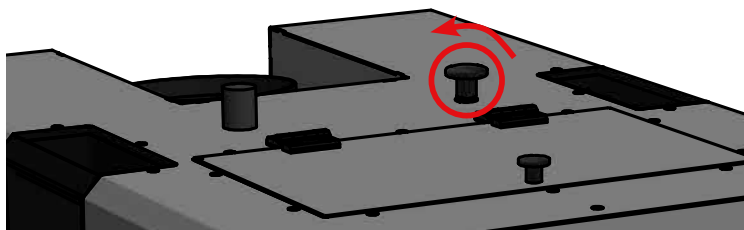
1**2**

Remove 21 screws circled red to remove the top cover with a TORX20 screwdriver.

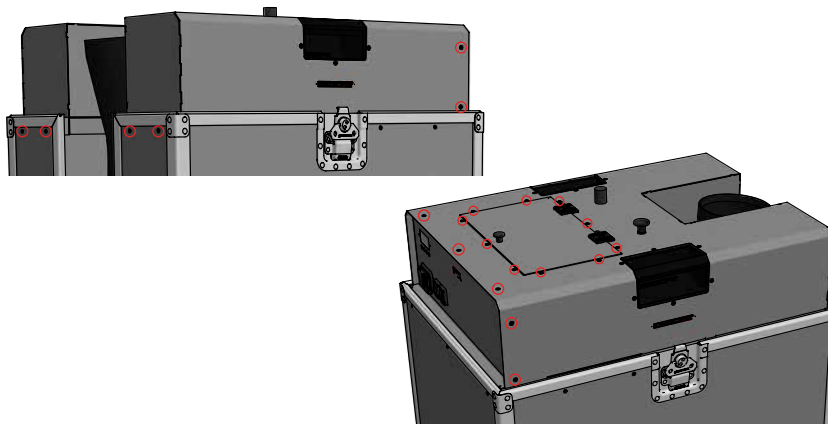

-
- 3 Take off the top cover.

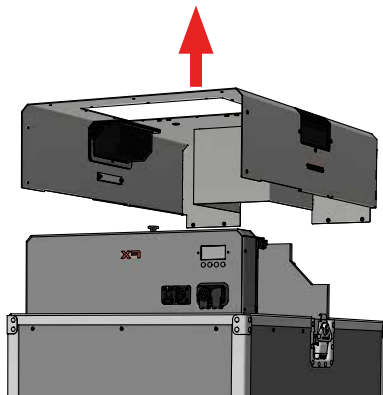

-
- 4 Remove the divider panel by sliding it out vertical.

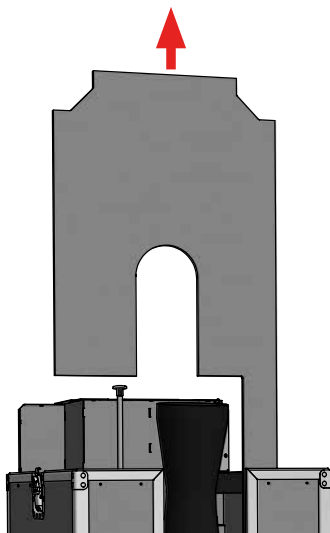

-
- 5** Unscrew the hose clamp from the hopper and remove the hose by turning the venturi nozzle.

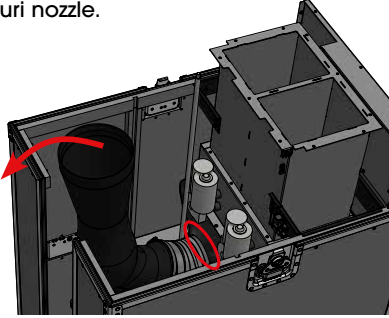

-
- 6** Disconnect the 3 connectors.

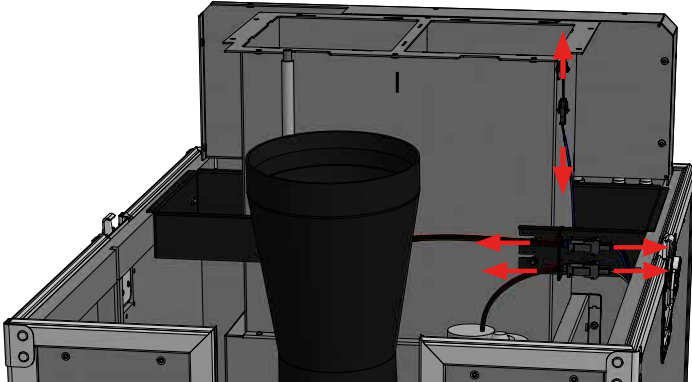

-
- 7** Remove 4 screws circled red to remove the hopper with a TORX20 screwdriver.

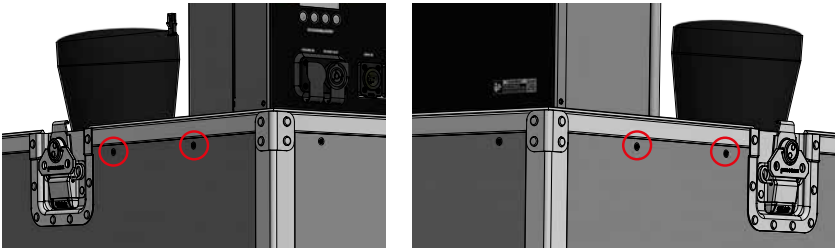

-
- 8** Take out the hopper carefully and place it on a stable surface with the motors facing down.

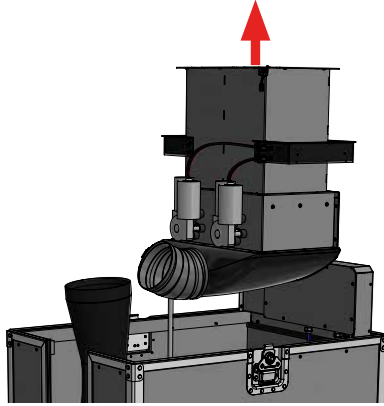

-
- 9** Remove 14 screws circled red and remove the plate with bearings with a TORX20 screwdriver.

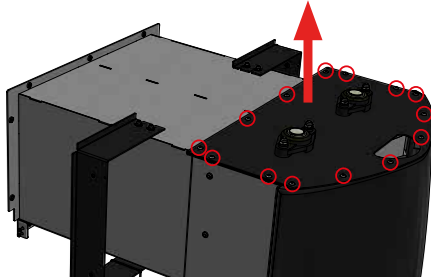

-
- 10** Take out the 2 adapters.

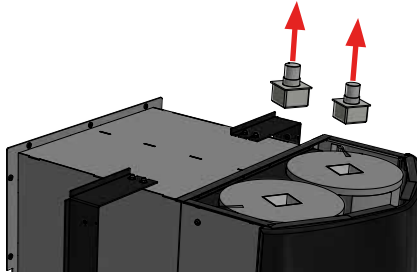

11 Take out the 2 rollers

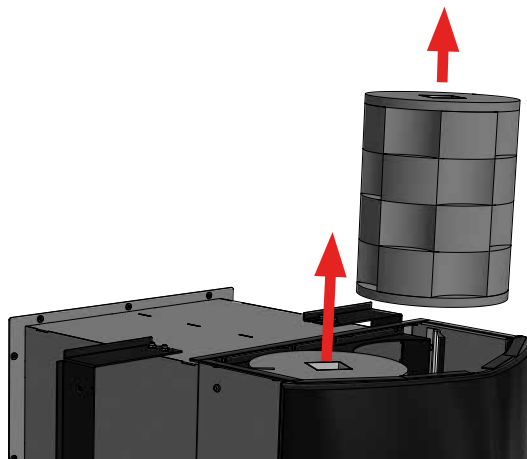

12 Put back 2 new rollers and assemble the product in reverse order.

5 TROUBLESHOOTING

In case the display shows one of the following error or alarm codes, act accordingly:

Code	Meaning	Solution
015	Fan not running at correct RPM	• Check if mains voltage is not too low (<210 VAC)
017	Hopper foam roller not at correct RPM	• Check hopper for blockages
100	Conflict between safety and functional DMX Addresses	• Change either safety or functional DMX start address
202	Conflict between safety and functional DMX addresses	• Reprogram the MFXOS with force of UID
203	Hopper lid open warning	• Close the lid completely / Repair the safety switch

Troubleshooting

Always contact MAGIC FX if any malfunctions or errors occur that cannot be solved with the instructions as described in this manual.

CORRECT DISPOSAL



This symbol on the product and / or accompanying documents means that used electrical and electronic products should not be mixed with general household waste. For proper treatment, recovery and recycling, please take this product to designated collection points where it will be accepted free of charge.



Alternatively, in some countries you may be able to return your products to your local retailer upon purchase of an equivalent new product.

Disposing of this product correctly will help save valuable resources and prevent any potential negative effects on human health and the environment, which could otherwise arise from inappropriate waste handling.

Please contact your local authority for further details of your nearest designated collection point.

Penalties may be applicable for incorrect disposal of this waste, in accordance with your national legislation.

6 EC DECLARATION OF CONFORMITY

According to Annex III A Machinery Directive 2006/42/EC

MAGIC FX B.V. declares as manufacturer and composer of the technical construction file that the product with the following specifications:

Name machine : STADIUMBLOWER®
Type : MFX0502
Voltage : 210-240Vac 50/60Hz
Serial number : on product
Year of construction : on product

Is in conformity with the minimal safety regulations as stated in the following directive(s):

- LVD (2014/35/EU) Low Voltage Directive
- EMC (2014/30/EC) ElectroMagnetic Compatibility
- RoHS (2011/65/EU) Restriction of the use of certain Hazardous Substances
- WEEE (2012/19/EU) Waste Electrical & Electronic Equipment

The following harmonized standards were applied:

- NEN-EN-ISO 12100:2010 Safety of machinery - General principles for design - Risk assessment and risk reduction.
- NEN-EN-IEC 60204-1:2018, Safety of machinery - Electrical equipment of machines - Part 1: General requirements.
- NEN-EN-IEC 61000-6-3:2007/A1:2011, Electromagnetic compatibility (EMC) - Part 6-3: Generic standards - Emission standard for residential, commercial and light-industrial environments.

- Original declaration of conformity
 Translation of the original declaration of conformity

Name manufacturer : MAGIC FX B.V.
Address : Schouwrooij 27, 5281 RE BOXTEL
Country : The Netherlands

CEO : B. Veroude
Date : 14-9-2020

Signature :



MAG:CFX[®]

WWW.MAGICFX.EU

